

Proven
Performance

McCloskey
INTERNATIONAL

407R



407R High Performance Trommel

The efficient McCloskey 407R Trommel leads the industry with a patented 180° radial stacking conveyor and a quick drum exchange system that allows an operator the flexibility of making screen changes in minutes not hours.

"We use the 407R for screening topsoil and crushed concrete and find the output is excellent for the size of the machine."

Paul Straughan
RJS Aggregates Ltd.
England



Options
Hopper extensions



Multiple drum
and screen
combinations



Features & Benefits

Adjustable Brushes - Ground level adjustable brushes retract for ease of drum change.

Feed Conveyor - Internal head drive 9' / 2.8m feeder with low load height hopper 9'8" / 2.9m.

Pintle Hitch - Removable drawbar for ease of towing.

Power Unit - 50 hp / 37 kw Tier III CAT diesel engine.

Radial Conveyor - Patented 180° remote controlled integrated radial stockpiling conveyor.



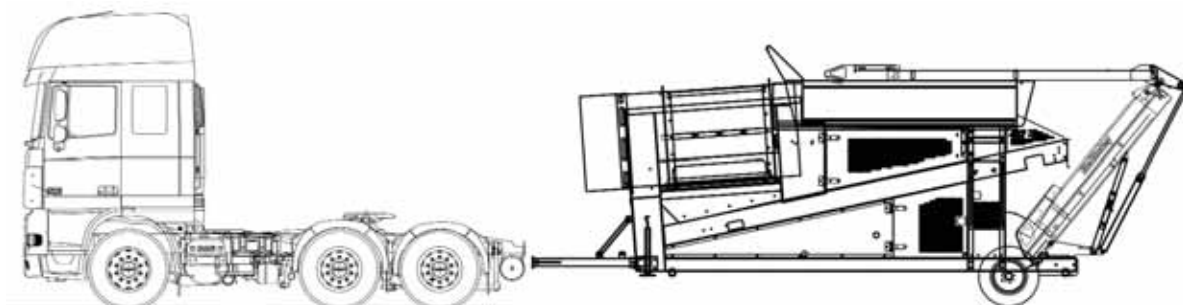
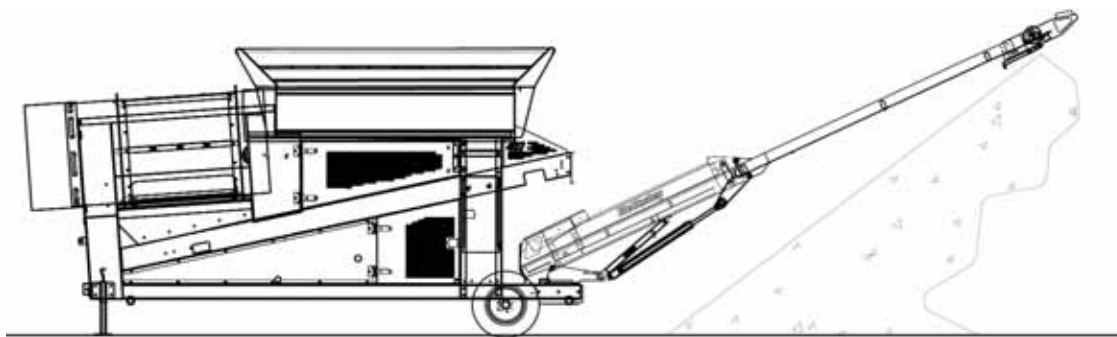

407R dimensions and weight

Trommel Screen	1.2 m x 2.1 m (4'-0" x 7'-0")
Weight	6,477 kg (14,877 lb)
Height Transport	3.4 m (11'-2")
Length Transport	8.6 m (28'-4")
Width Transport	2.4 m (8'-0")

Working dimensions

Height Working	3.8 m (12'-7")
Length Working	12.4 m (40'-6")
Width Working	2.4 m (8'-0")



N.America & S.America
 #1 McCloskey Road, RR#7
 Peterborough, Ontario Canada,
 K9J 6X8
 1-877-Trommel
 T (705) 295-4925
 F (705) 295-6159
 sales@mccloskeyinternational.com

UK & International
 47 Moor Road,
 Coalisland,
 Co Tyrone,
 N.Ireland BT71 4QB
 T +44 (0) 2887-740-926
 F +44 (0) 2887-747-242
 salesuk@mccloskeyinternational.com

McCloskey International reserves the right to make changes to the information and design of the machines on this brochure without reservation and notification to the users. McCloskey International assumes no liability resulting from errors or omissions in this document.

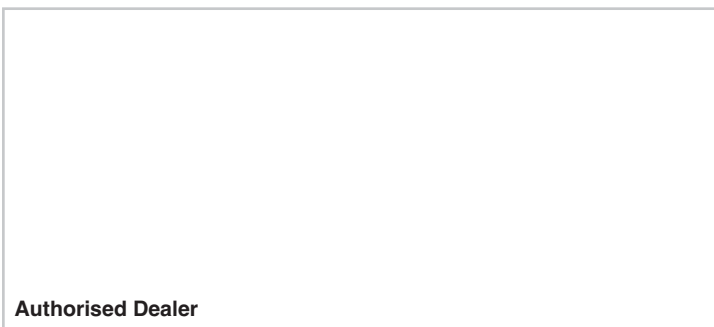

Authorized Dealer

Durability

Branded components throughout, including CAT Engine.

High efficiency diesel hydraulic system allows higher throughput and lower fuel consumption.

4 wheel drive drum system eliminating chain drives.

Vulcanized belts with high quality scrapers.



Maintenance/User friendly

Remote control radial conveyor.

Accessible engine bays at ground level.

Universal user friendly controls throughout the McCloskey line.

Quick setup time.

Highly maneuverable on site.

Unique user friendly belt adjusters.

Chain free drum and feed conveyor design.

Ground level grease points.

Stabiliser support legs.



See it in action...
 View working videos, customer testimonials and more at
www.mccloskeyinternational.com